



CKL

District cooling substations for commercial, industrial and residential buildings

Substations with plate heat exchangers for cooling applications. Designed for floor-mounting.

Application

District cooling can be defined as centralised production and distribution of cooling energy from the cooling plant to the industrial, commercial and residential buildings to cool the indoor climate. The DHC substations are used in the process of distributing cooling energy into the building.

When using district cooling, individual buildings do not need traditional chillers. The cooling substation needs significantly smaller space when compared with the space taken by the traditional equipment. The cooling substation does not include hazardous refrigerants, both primary and secondary sides are filled with water. When using centralised production, the energy is used efficiently. The end-user finds the centralised cooling easy and comfortable to use. Noises and vibrations caused by the traditional chillers disappear.

DHC Substation types

A standard range of CKL substations includes nine substations in different sizes and capacities. When necessary, tailored cooling substations are designed and manufactured according to specifications and requirements given by the customer.

Primary side, District Cooling (DHC)

The primary side of CKL substation is made with welded or flanged pipes and components designed for low supply temperature.

Secondary side, Cooling (CO)

The cooling circuit consists of e.g. one or more gasketed or brazed plate heat exchangers with thermal insulation, electronic controls, safety valve, manometers, thermometers, ball valves, strainer, shut-off valves, filling valves and circulation pump. The cooling temperature is controlled by an electronic controller with temperature sensors.

Design

The CKL substations are fitted with plate heat exchangers. The heavy turbulence and counterflow principle enable efficient heat transfer. The CKL substations are supplied with internal electrical connections. The design is based on a 3D modeling and highly developed modular system. With professional design process the CKL substations are compact in structure. The substations are built with prefabricated parts made with automated pipe welding and bending equipment giving supreme quality and short delivery time.

Information needed for a quotation

- Cooling capacities
- Temperature programmes
- Permitted pressure losses in the heat exchangers / substations
- Primary pressure difference available
- Pressure losses in secondary circuits
- Circuit diagram or other information on the components required

FEATURES AND BENEFITS

- Substations with high-quality components for cooling commercial and industrial buildings and apartments
- Energy efficient, environmentally friendly solution
- Fast delivery for the standard types
- Customized substations available
- Extremely high output
- Compact structure
- Easy to install and use
- Quiet cooling solution
- ISO 9001 and ISO 14001 certificates
- Danfoss substations are manufactured according to PED 97/23/EC

CKL

Circuit diagram - example

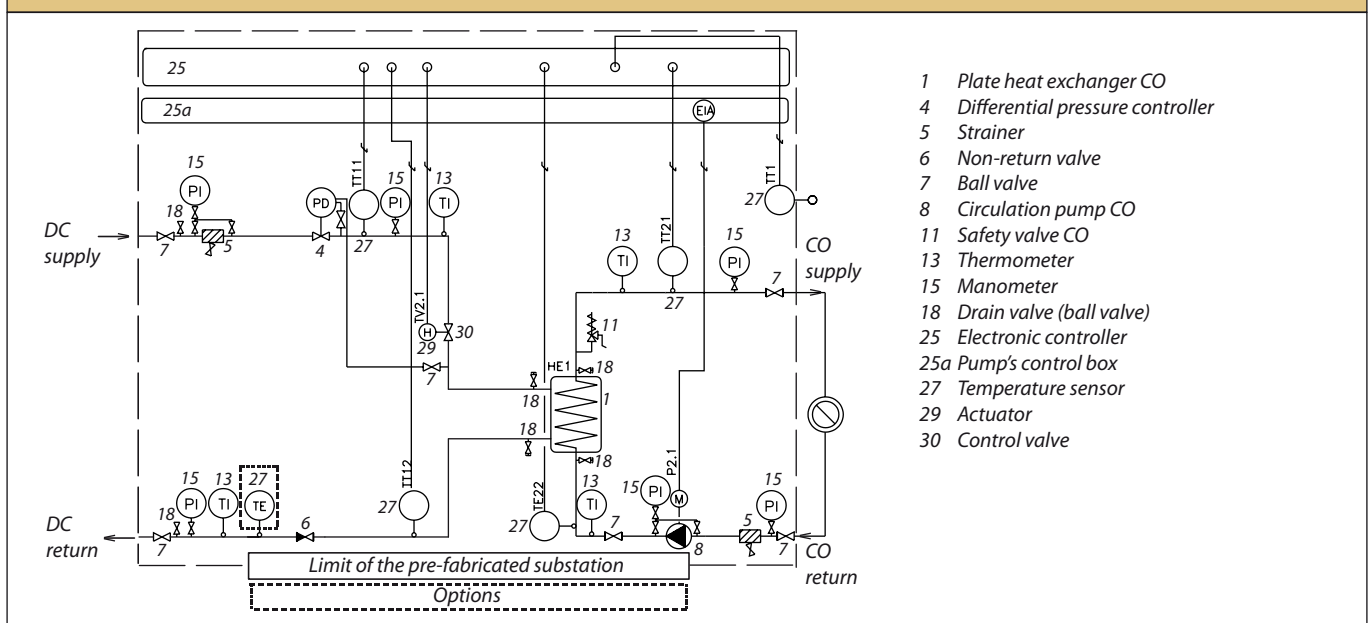

- 1 Plate heat exchanger CO
- 4 Differential pressure controller
- 5 Strainer
- 6 Non-return valve
- 7 Ball valve
- 8 Circulation pump CO
- 11 Safety valve CO
- 13 Thermometer
- 15 Manometer
- 18 Drain valve (ball valve)
- 25 Electronic controller
- 25a Pump's control box
- 27 Temperature sensor
- 29 Actuator
- 30 Control valve

Example of a standard district cooling substation

Technical parameters

Nominal pressure
 PN 10/16/25
 DC supply temperature
 $T_{min} = 3\text{ }^{\circ}\text{C}$
 $T_{max} = 90\text{ }^{\circ}\text{C}$

Electrical supply
 230/400 VAC

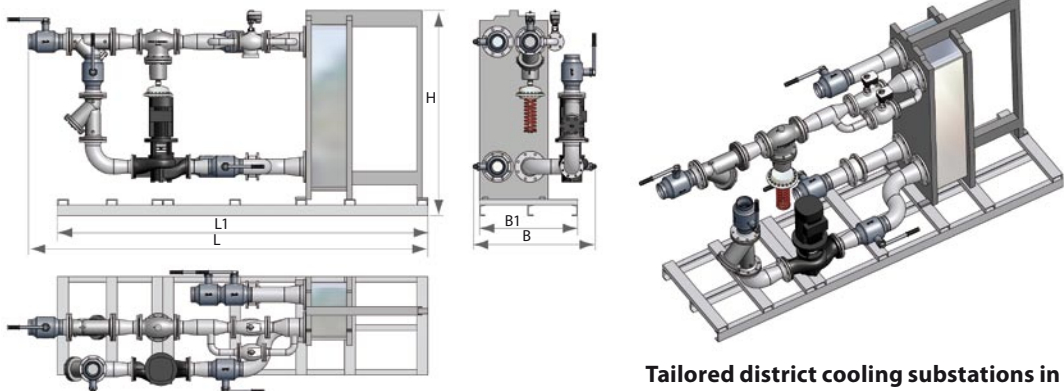

Tailored district cooling substations in all sizes

District cooling substations can be tailored to meet the desired capacities and dimensions.
 Pipe connections: DN 25 ... DN 500
 Capacities: 50 kW... 20 MW

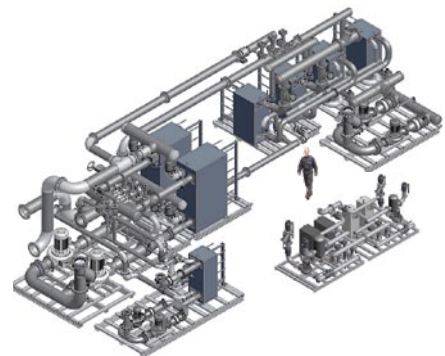

Capacity and dimensions examples

Type	Capacity kW	Pipe connection DN		Dimensions				
		CO	DC	L mm	L1 mm	B mm	B1 mm	H mm
CKL-100	100	50	50	2350	2100	420	420	1530
CKL-250	250	65	65	2640	2400	600	600	1780
CKL-500	500	100	100	3180	2800	600	600	1780
CKL-750	750	100	100	3410	3200	600	600	1780
CKL-1000	1000	125	125	3670	3400	1160	900	1880
CKL-1250	1250	150	150	4250	3800	1260	1000	1880
CKL-1500	1500	150	150	4220	3800	1260	1000	1880
CKL-1750	1750	200	200	4930	4500	1460	1100	1880
CKL-2000	2000	200	200	4930	4500	1460	1100	1880

Oy Danfoss Ab · Danfoss LPM · Box 19 · 79101 Leppävirta · Finland

Phone: +358 403 092 200 · Fax: +358 403 092 281 · sales@danfoss.com · www.danfoss.com · www.lpm.danfoss.fi

Danfoss can accept no responsibility for possible errors in catalogues, brochures and other printed material. Danfoss reserves the right to alter its products without notice. This also applies to products already on order provided that such alterations can be made without consequential changes being necessary in specifications already agreed. All trademarks in this material are property of the respective companies. Danfoss and the Danfoss logotype are trademarks of Danfoss A/S. All rights reserved.